

MV2400-R

**New Larger Travels
23.6 x 15.7 x 12.2**

ADVANCE PLUS

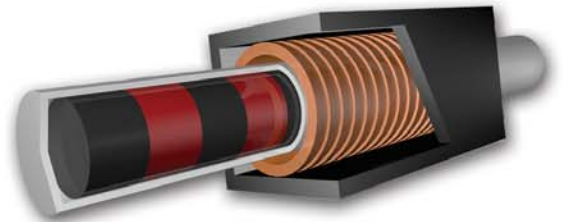

All New Cylindrical Drive Technology

The MV Series utilizes a totally new non-contact, friction free, round linear shaft motor system to drive the X Y U & V machine axes through an all optical fiber servo system.

Features:

- **New Machine Size Is Specifically Designed For Larger Part Production** The MV-2400-R provides a larger worktank, increased travels by 4 inches in X, 2 inches in Y over the FA20 size machine. This added size along with all the new cost saving designs, make this the best dollar/sq. ft. EDM investment on the market.
- **New Linear Shaft Motor Drive and Glass Scale Feedback** insure friction free, highly accurate column movement throughout the entire X Y U V Axes machining range.
- **Highly Rigid Machine Structure** incorporates meanite base castings, a stainless steel work tank, seal plate and machine table to provide high accuracy machining.
- **V350-V Full Time AE II (Anti-Electrolysis) Power Supply** suppresses electrolytic corrosion to prevent surface oxidation, edge softening and cobalt depletion in carbide.
- **DMX-S (Digital Matrix Sensor)** combined with the V350-V generator specifically shapes the spark pulse to reduce electrode wear. This allows for a lower wire speed which reduces wire cost by as much as 60%.
- **New Intelligent Auto-Threading System** has been redesigned to anneal up to 14" of wire reducing the curl ratio to less than 10% improving tall part threading as well as submerged threading and re-threading through the gap after a wire break.
- **Powerful Support Functions Improve Productivity** The M700 Advance Plus series control uses Windows XP operating system with many levels of automated machine functions to allow even an inexperienced operator to cut parts with confidence.

MV-R Series **R**evolutionary Productivity Improvements



Intelligent AT

Advanced wire annealing at over 14" in length reduces wire curl to less than 10% improving tall part threading and reinsert through the gap while submerged.

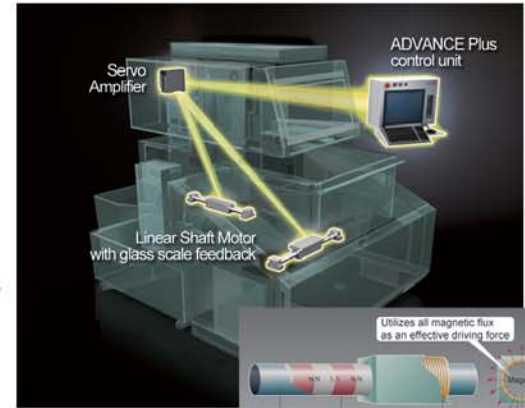

The new Advance Plus control combined with the Optical Drive System provides 4 times the communication speed between the servo system and the XYUV axes Linear Shaft Motor drives.



The V350-V power supply and DMX-S, Super Digital Control sensor, specifically shape each spark to improve surface finish, reduce vibration and minimize electrode wear. This reduction in wear allows up to a 60% reduction in wire consumption.

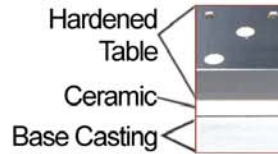

The Precision Finish Circuit uses a ceramic insulator between the table base casting and the new hardened SS work table reducing impedance which improves FM surface finish.

MV2400-R/S Front View

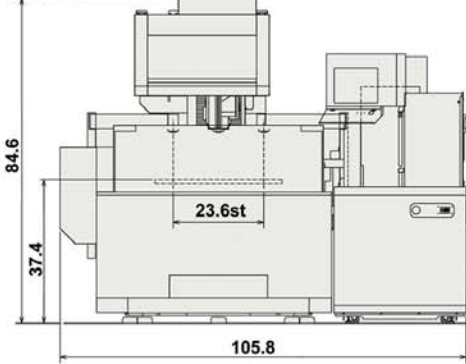

MV2400-R/S Layout Drawing

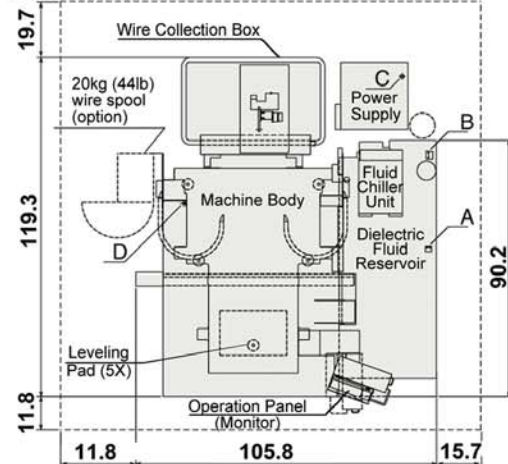

Machine Specifications		MV2400-R
Machine Unit	Max Workpiece Dimensions (WxDxH)	in 41.3 x 32.3 x 12.0
	Max Workpiece Weight	lb. 3307
	Table Dimensions	in 33.0 x 25.2
	Machining Range (XxYxZ)	in 23.6 x 15.7 x 12.2
	Wire Dia. by AT Device	in .004 ~ .012
	Wire Tension	g 200 ~ 2550
	Automatic Wire Threader	Standard
	Min. Start Hole Dia.	in 0.02
	Taper Machining Unit	Standard
	Taper Unit Travel (U x V)	in ±3.0 x ±3.0
	Max. Taper Angle	deg 15 deg @ 10.25" Thickness
	Overall Machine Dimensions (WxDxH)	in 105.8 x 119.3 x 84.6
Machine Weight	lb. 7716	
Fluid System	Tank Capacity	gal. 227
	Filtered Particle Size	µm 3
	Filter Elements	2 / Paper
	Ion Exchange Resin	cu/ft 1
	Overall Dimensions	in 34.6 x 82.1 x 52.6
Dry Weight	lb. 880	

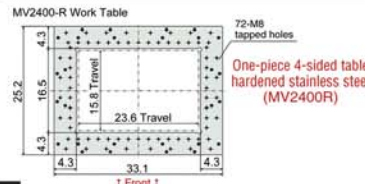

MC Machinery Systems Inc.
1500 Michael Drive
Wood Dale, IL 60191
Phone: (630) 616-5920
Fax: (630) 616-4068
www.mitsubishi-world.com